

# Lipper

International Inc.

235 Washington Street, Wallingford, CT 06492  
Tel. (800) 243-3129

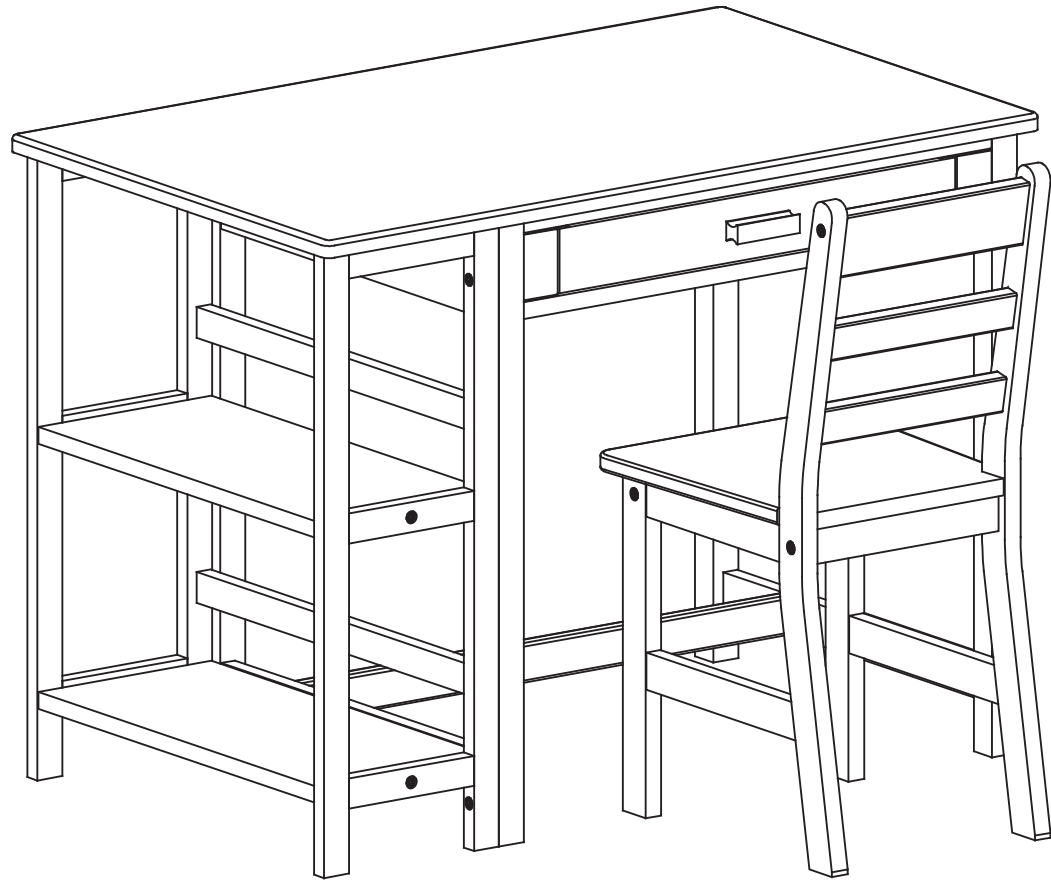

Assembly Instruction Sheet  
Item # 584  
***Workstation Desk/Chair***

# Assembly Instruction : Desk

CAUTION: Hardware Assembly Package Contains Small Parts  
Adult Assembly Required

## Parts

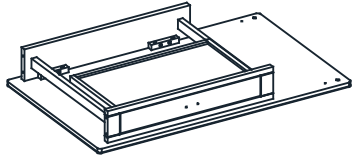

Desktop (A)  
1 Pc.

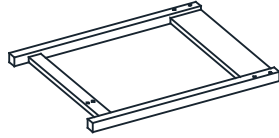

Left Panel (B)  
1 Pc.

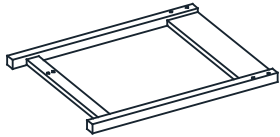

Right Panel (C)  
1 Pc.



Leg Crossbar (D)  
1 Pc.

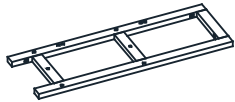

Front Panel (E)  
1 Pc.

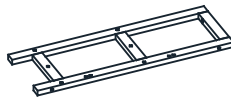

Back Panel (F)  
1 Pc.



Shelves (G)  
2 Pcs.



Shelves Crossbar (H)  
2 Pcs.

## Hardware



Handle  
1 Pc.



Screw Handle  
2 Pcs.



Short Screw  
8 Pcs.

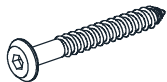

Large Screw  
12 Pcs.



Allen Key  
1 Pc.

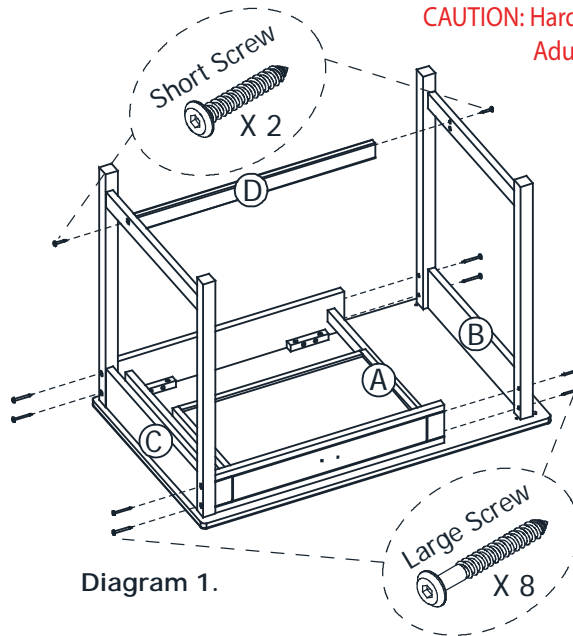

Diagram 1.

Invert Desktop (A) on a soft surface.  
Attach left Panel (B), Right Panel (C),  
Leg Crossbar (D) and Desktop (A) together  
using 8 Large screws and 2 Short Screws as per diag.1.

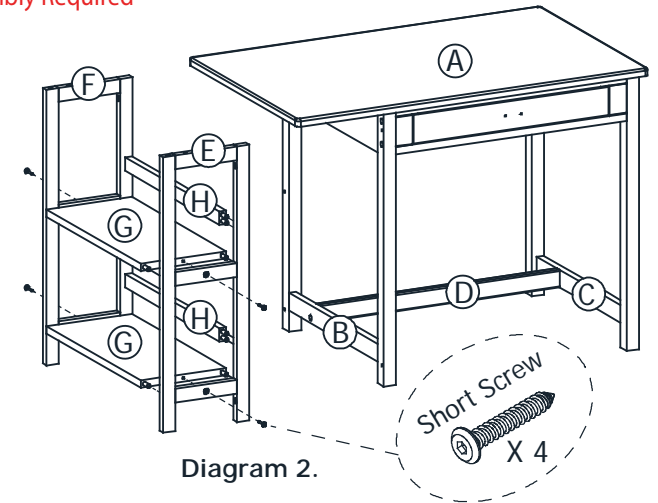

Diagram 2.

Attach Front Panel (E), Back Panel (F),  
Shelves (G) and Shelves Crossbar (H)  
together using 4 Short Screws as per diag.2.

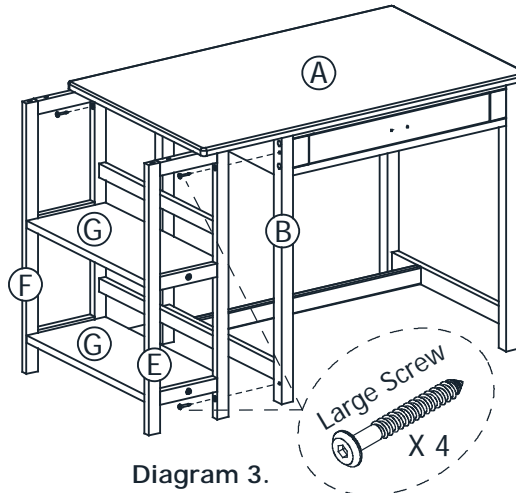

Diagram 3.

Attach the unit of shelves into the Left Panel (B)  
using 4 Large Screws as per diag.3.

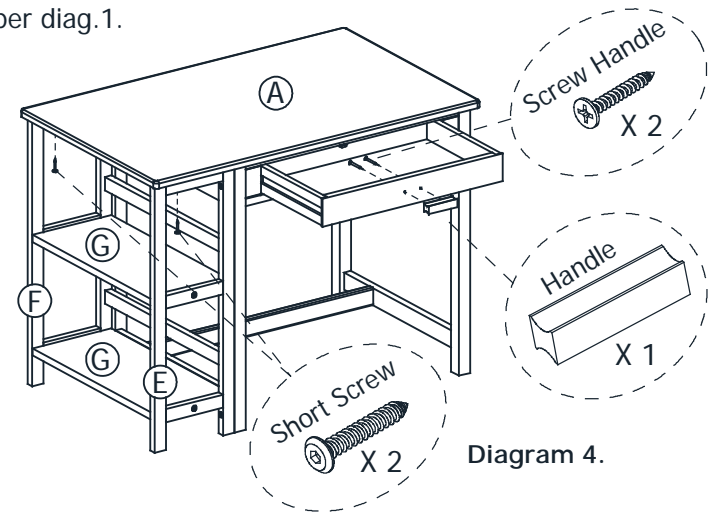
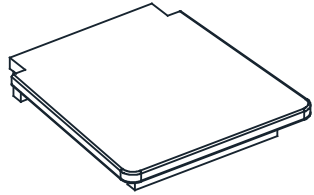

Diagram 4.

Fit the Front and Back Panel (E&F) into the Desktop (A)  
using 2 Short Screws, Then attach handle into  
the drawer using 2 Screw Handle as per diag.4.

# Assembly Instruction : Chair

## Parts



Seat (I)  
1 Pc.

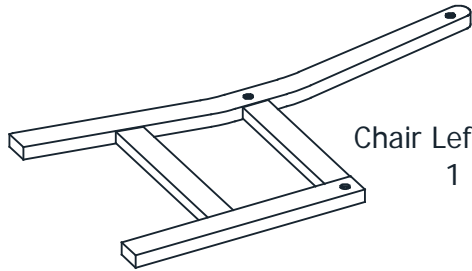

Chair Left Frame (J)  
1 Pc.

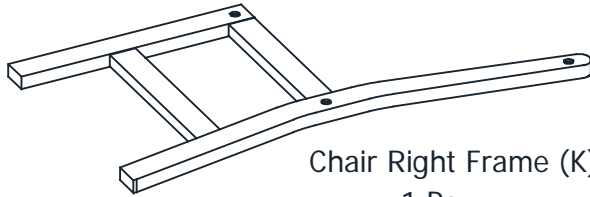

Chair Right Frame (K)  
1 Pc.



Top Back Rest (L)  
1 Pc.



Middle Back Rest (M)  
2 Pcs.

## Hardware



Short Screw  
6 Pcs.



Allen Key  
1 Pc.

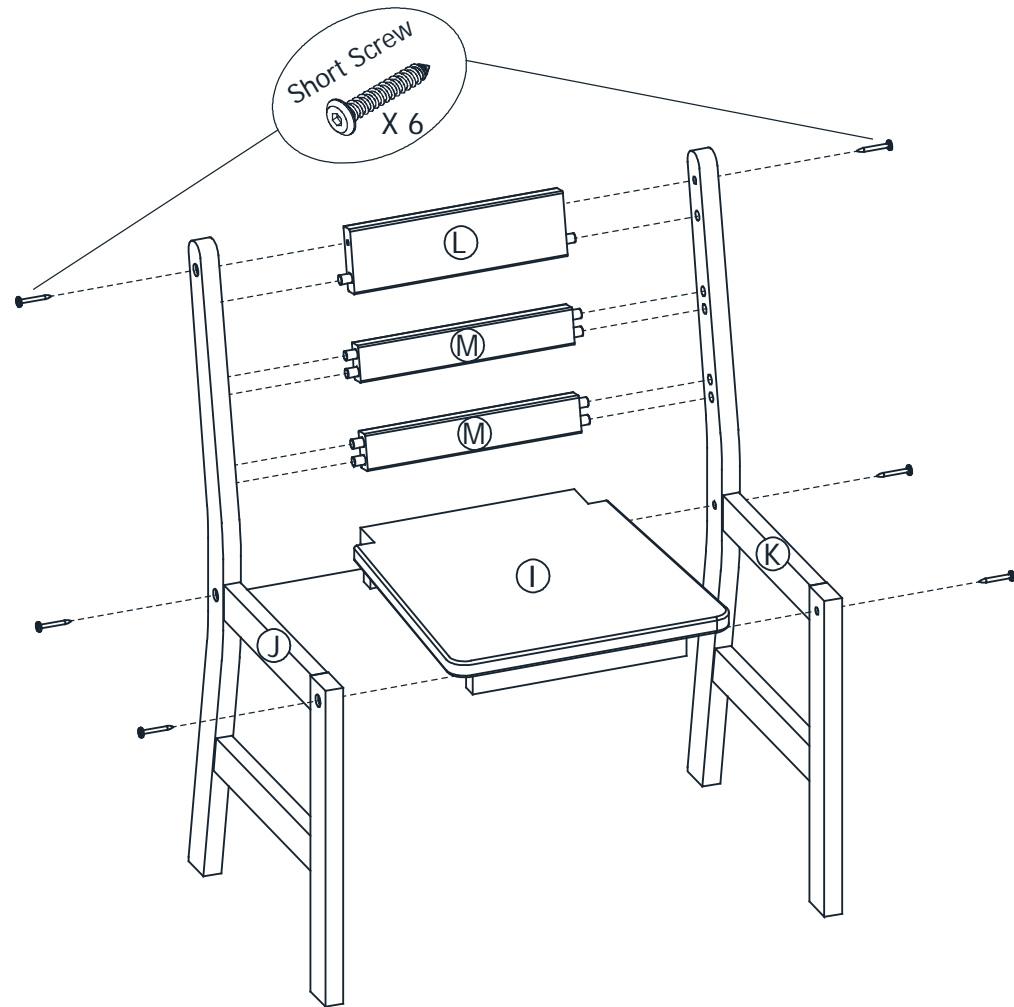

Assembled the chair by attaching Seat (I), Chair Left Frame (J), Top Back Rest (L), Middle Back Rest (M) and Chair Right Frame (K) together using 6 Short Screw as per diag.